

HV ROUTINE TEST FIELDS FOR EXTRUDED POWER CABLES

- **Complete solutions including comprehensive technical support**
- **Reliable performance for even the highest cable ratings and testing levels**
- **Highest PD measuring sensitivity**
- **Power upgrades for testing of even ultralong power cables**

HV ROUTINE TEST FIELDS FOR EXTRUDED POWER CABLES

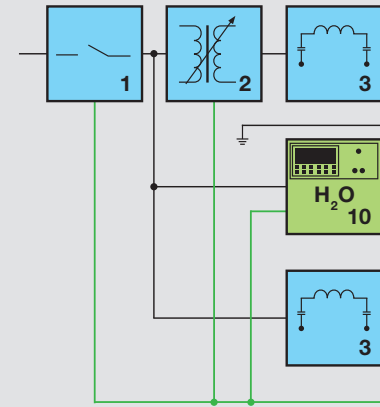

Fig. 1 Test field for 500 kV cables with routine WRM test system with 800 kV and 28,000 kVA

FACTS IN BRIEF

The routine testing of power cables is an essential part of the manufacturing process and verifies both the correct production steps and the appropriate material quality. HIGHVOLT supplies complete routine test fields and individual testing components. Our many years of experience in this field result in outstanding performance in terms of:

- High reliability and low maintenance
- High PD measuring sensitivity even on long cables
- Optimum configurations adapted to customer's conditions
- Operator-friendly control and measurement with only one computer
- Full support starting from project consultancy to commissioning, from training of operating personnel and preventive maintenance to after-sales service

The proper selection of test systems, components and accessories according to the cables to be tested and their test parameters means routine test fields are smoothly integrated in the entire cable manufacturing process.

BENEFITS

- COMPLETE SYSTEM SOLUTIONS
- HIGH PD MEASURING SENSITIVITY
- OPTIMUM SHIELDED ROOM DESIGN
- IDEAL SINUSOIDAL TEST VOLTAGE

APPLICATION

HIGHVOLT cable test fields enable routine testing of extruded power cables according to the relevant standards, such as IEC 60502 (1 kV to 30 kV, MV cables), IEC 60840 (30 kV to 150 kV, HV cables) and IEC 62067 (150 kV to 500 kV, EHV cables) for each delivery length after production. The tests include the following procedures:

- **HVAC withstand tests** are mandatory and performed with test voltages ranging between $4 U_0$ for medium-voltage cables down to $2 U_0$ for ultra-high-voltage cables.
- **Partial discharge (PD) tests** are able to detect even very small weak points in the cable insulation. Therefore the PD test needs to be extremely sensitive.
- **HiRES Locator - a breakdown localization device**
The localization of a breakdown during HV testing is time-consuming and thus cost-intensive. Therefore, the HiRES Locator can be used during testing and no additional measuring time for the breakdown localization is needed.

- SPECIAL SOLUTIONS FOR TESTING OF ULTRALONG CABLES
- INTERFERENCE-FREE CONTROL
- ONLY ONE CENTRAL COMPUTER CONTROL
- CUSTOMIZED TEST REPORTS

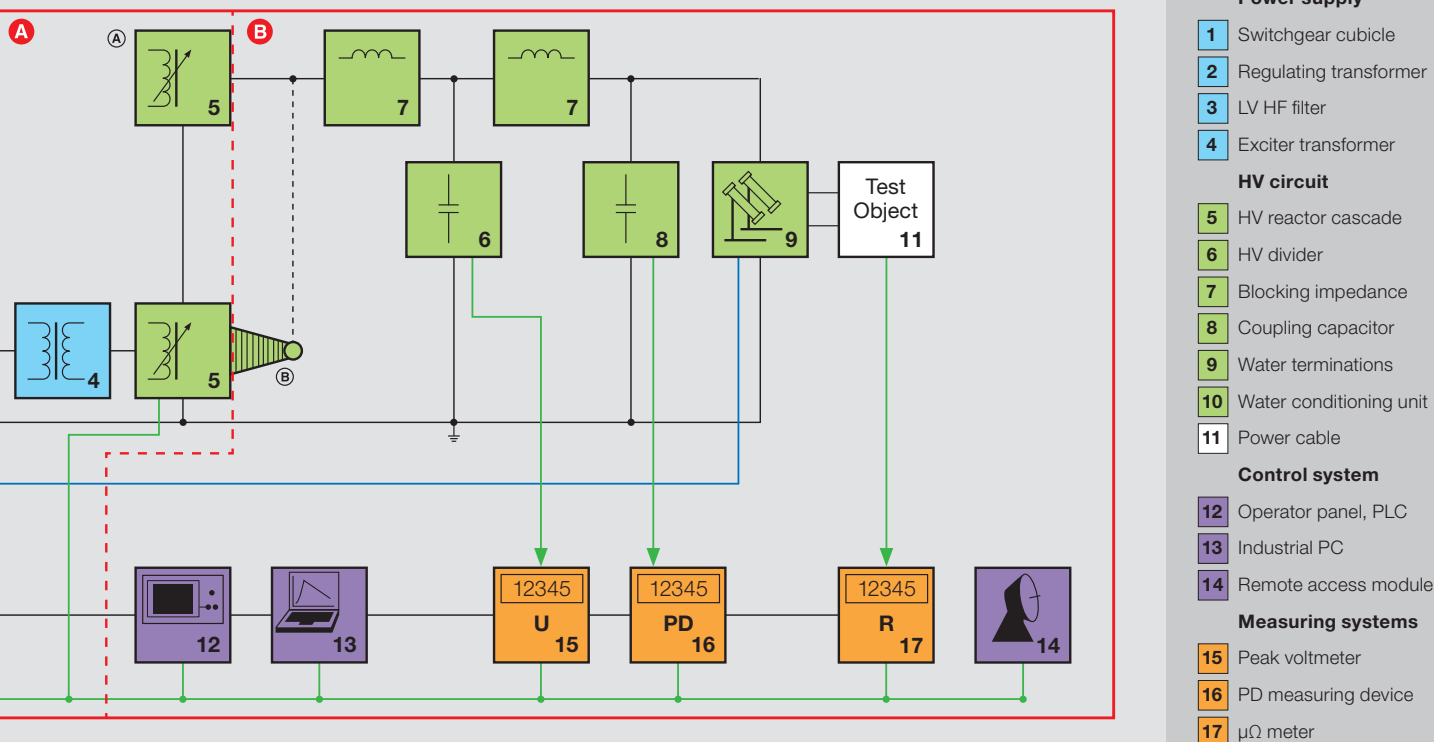

Fig. 2 Principle single-line diagram of cable routine test field

SYSTEM AND COMPONENTS

Most of the components of the routine test field are installed inside a shielded test room (Faraday cage or electromagnetic screen) to guarantee the required high PD measuring sensitivity [see fig. 2]. There are two different basic versions for the configuration depending on the HV reactor type installed:

(A) is the configuration for implementation of **HV modular reactors (5)** or reactor cascades. The feeding power passes the switchgear cubicle (1), regulating transformer (2) and low-voltage (LV) high-frequency (HF) filter (3). The latter is attached to the room wall and efficiently suppresses the line-connected electromagnetic interferences. All other components are installed inside the shielded room. The interference-free design of the water conditioning unit (10) makes it possible to install it inside or outside the shielded room.

(B) is the configuration for **HV metal tank reactors (5)**. The reactor tank is directly flanged to the room wall and its HV bushing projects into the shielded room. In general the exciter transformer (4) is incorporated in the steel tank of the HV reactor and the LV HF filter (3) is mounted on the reactor tank. This provides same high-efficient noise suppression as described in (A). The principle of the HV resonant circuit and of the power supply is the same for either version (A) or (B). Only the power loss of the testing configuration has to be fed from the LV or MV mains. The regulating transformer adjusts the value of the feeding voltage and the exciter transformer with taps (4) matches it to the required voltage of the resonant circuit. The inductance of the

HV reactor (5) together with the HV capacitors (6, 8) and the capacitance of the cable to be tested (11) form the HV resonant circuit. The capacitance value of the HV capacitors (basic load) is selected even to generate resonance without the connected test object for no-load operation of the test system.

The HV filter (L-C-L-C combination) fulfils several functions in terms of protection (blocking impedance (7)) and measurement. Its precise design is a further precondition for sensitive PD measurement.

Special testing terminations (9) based on transformer oil (up to 100 kV) or deionized water (10) (up to 800 kV) are applied on the cable ends. One of the ends is connected with the HV coupling capacitor (8) by a PD-free HV lead.

The capacitive HV divider (6) feeds the peak voltmeter (14) for processing and evaluating of the test voltage. The HV coupling capacitor (8) supplies the PD signal to the PD measuring device (16).

The control and measuring system is the combination of the HV basic control (12) including voltage measurement with the advanced computer control (13), as well as all other measuring devices. It enables full automation of the test procedures, data processing and recording and generation of customized test reports.

HV ROUTINE TEST FIELDS FOR EXTRUDED POWER CABLES

TECHNICAL PARAMETERS

Systems with modular reactors type WRM

Configuration (A)

- Routine testing of cables rated up to 550 kV
- Cable lengths to be tested up to 2000 m and more
- Rated voltages from 250 kV to 800 kV
- Typical rated power up to 56000 kVA

Systems with metal tank reactors type WR

Configuration (B)

- Routine testing of cables rated up to 245 kV
- Cable lengths to be tested up to 1000 m and more
- Rated voltages from 35 kV up to 350 kV
- Typical rated power up to 10000 kVA

General information/Configurations (A) and (B)

- Higher power and voltage ratings can be achieved by parallel or series operation of several HV reactors
- Subsequent power and voltage upgrade also possible
- PD measuring sensitivity better than 2 pC
- Tan delta measurement with compressed gas standard capacitors up to 800 kV and with resolution of 10^{-5}
- Cable terminations up to 800 kV AC with high-precision water conditioning unit for conductivity adjustment down to 0.1 $\mu\text{S}/\text{cm}$ and cooling power up to 240 kW
- Shielded room with all technical accessories such as built-in control room, operator desk, cable drum access door, personnel doors, lighting, security measures (optional accessories: ventilation, air conditioning, crane)
- Project consulting with layout proposals, recommendations for grounding and safety aspects

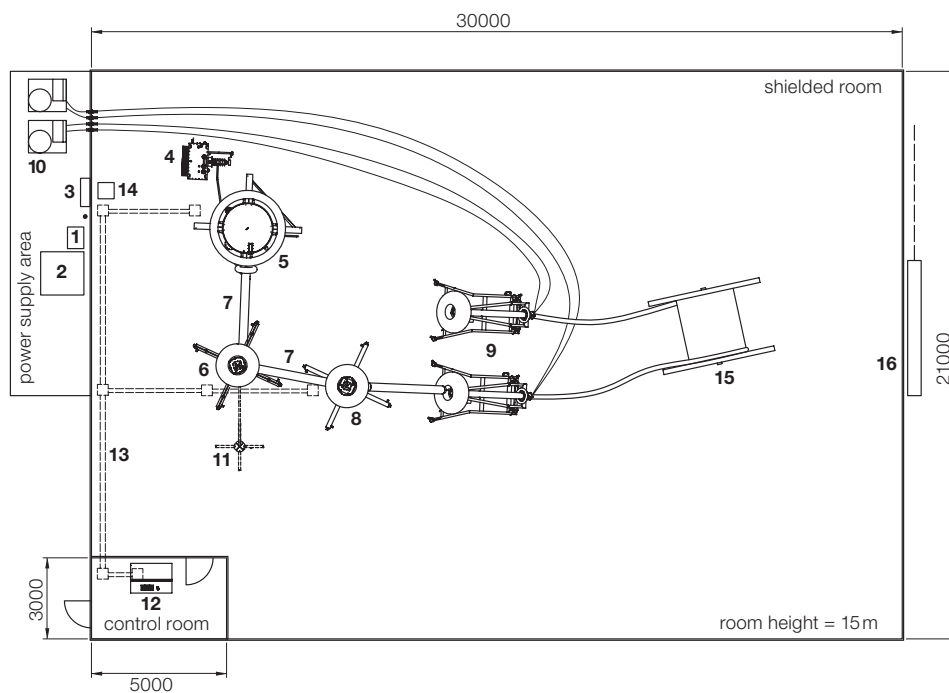

Fig. 3 Typical layout of a test field for routine testing of EHV cables (Configuration A)

Power supply

- 1 Switchgear cubicle
- 2 Regulating transformer
- 3 LV HF filter
- 4 Exciter transformer

HV circuit

- 5 HV reactor cascade
- 6 HV divider
- 7 Blocking impedance
- 8 Coupling capacitor
- 9 Water terminations
- 10 Water conditioning unit
- 11 Connection for parallel operation

Control system

- 12 Operator desk
- 13 Cable duct
- 14 Control cabinet

Miscellaneous

- 15 Cable to be tested
- 16 Access door

For further information please contact:

HIGHVOLT Prüftechnik Dresden GmbH

Marie-Curie-Straße 10
01139 Dresden
Germany

Phone +49 351 8425-700
E-mail sales@highvolt.com
Web www.highvolt.com